



NSW Education Standards Authority

2020 HIGHER SCHOOL CERTIFICATE EXAMINATION

Physics

**General
Instructions**

- Reading time – 5 minutes
- Working time – 3 hours
- Write using black pen
- Draw diagrams using pencil
- Calculators approved by NESA may be used
- A data sheet, formulae sheet and Periodic Table are provided at the back of this paper

**Total marks:
100**

Section I – 20 marks (pages 2–16)

- Attempt Questions 1–20
- Allow about 35 minutes for this section

Section II – 80 marks (pages 17–36)

- Attempt Questions 21–34
- Allow about 2 hours and 25 minutes for this section

Section I

20 marks

Attempt Questions 1–20

Allow about 35 minutes for this section

Use the multiple-choice answer sheet for Questions 1–20.

- 1 The diagram shows a model used to explain the refraction of light passing from medium X into medium Y.

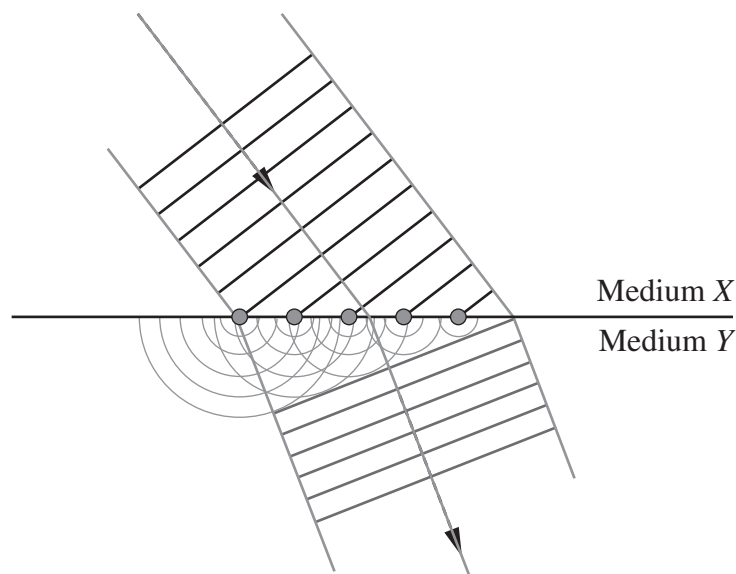

- Who proposed this model?
- A. Malus
 - B. Planck
 - C. Newton
 - D. Huygens
- 2 Which of the following is NOT required for the operation of AC induction motors?
- A. Brushes
 - B. Stator winding
 - C. Magnetic fields
 - D. Current applied to the rotor

- 3 What was the basis for Maxwell's prediction of the velocity of electromagnetic waves?
- Experiments using magnetic fields to accelerate particles
 - Experiments using light and mirrors to establish the finite speed of light
 - Equations showing how oscillating electric and magnetic fields propagate
 - Equations showing how electromagnetic waves are affected by gravitational fields
- 4 The graph shows the mass of a radioactive isotope as a function of time.

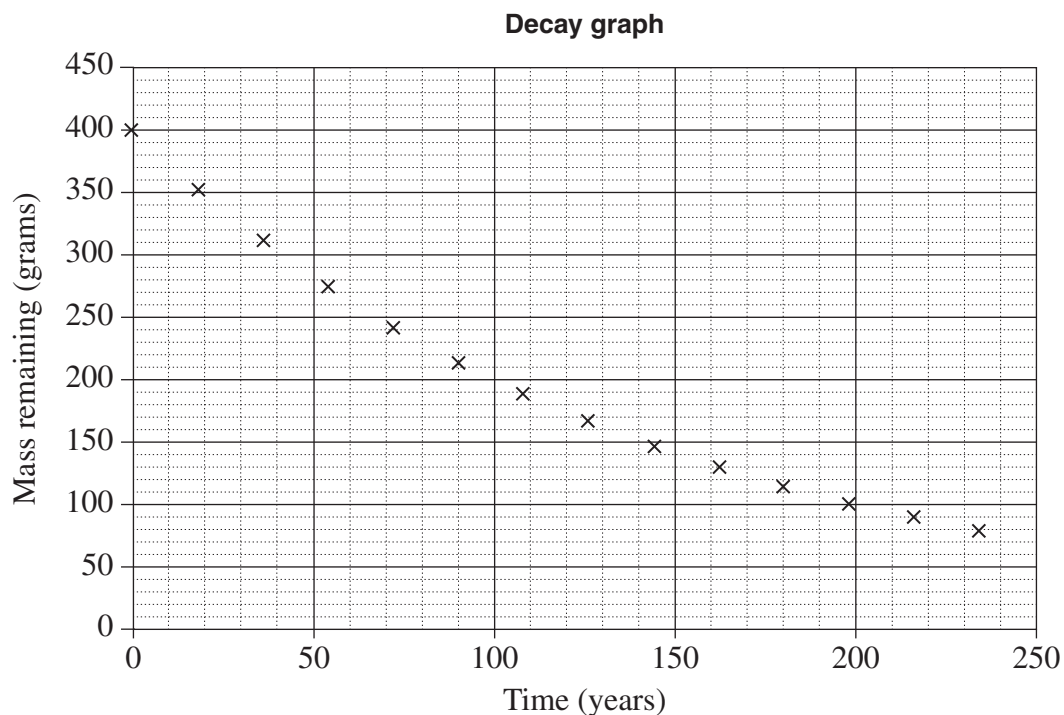

What is the decay constant, in years^{-1} , for this isotope?

- 0.0030
- 0.0069
- 2.0
- 100

5 A student throws a ball that follows a parabolic trajectory.

What change to the initial velocity would make the ball's time of flight shorter?

- A. Increasing only the vertical component
- B. Decreasing only the vertical component
- C. Increasing only the horizontal component
- D. Decreasing only the horizontal component

6 The Hertzsprung–Russell diagram shows characteristics of stars in a globular cluster 100 light years in diameter and 27 000 light years from Earth.

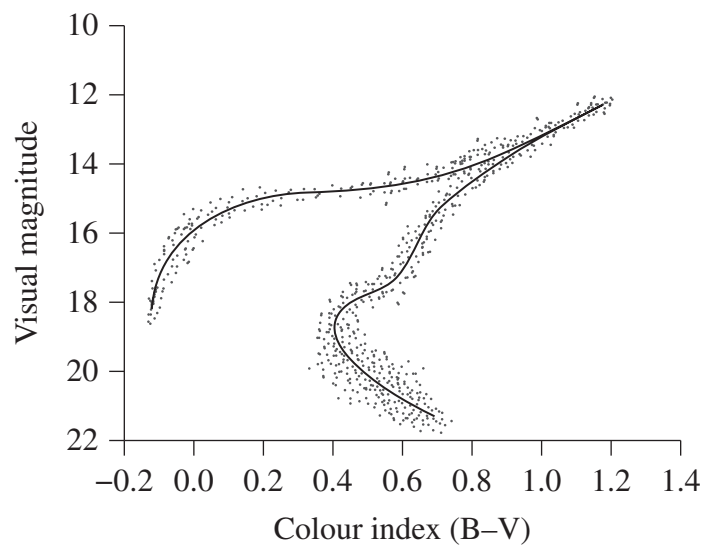

The stars plotted on this Hertzsprung–Russell diagram have approximately the same

- A. age.
- B. colour.
- C. luminosity.
- D. mass.

7 The output of a device is shown.

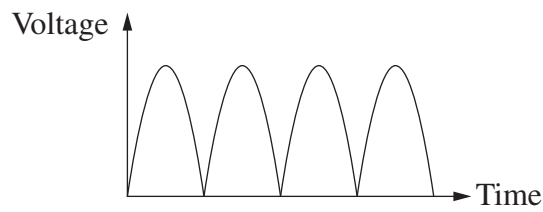

Which diagram represents the device that has the output shown?

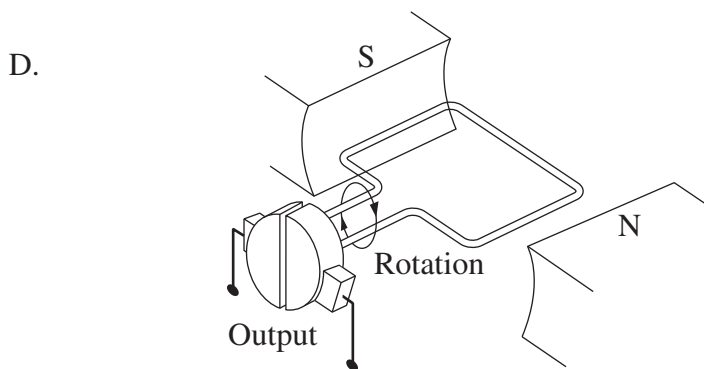
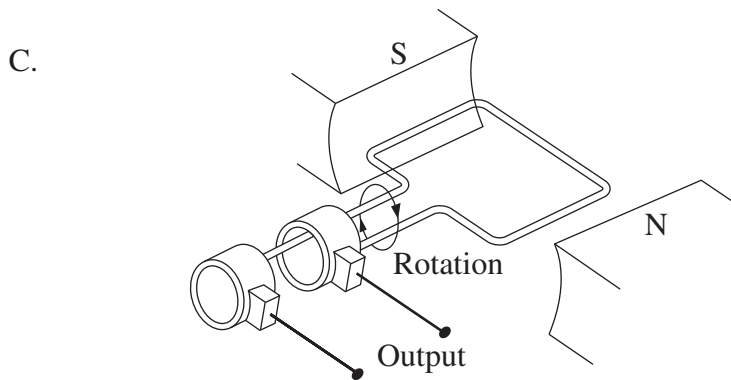
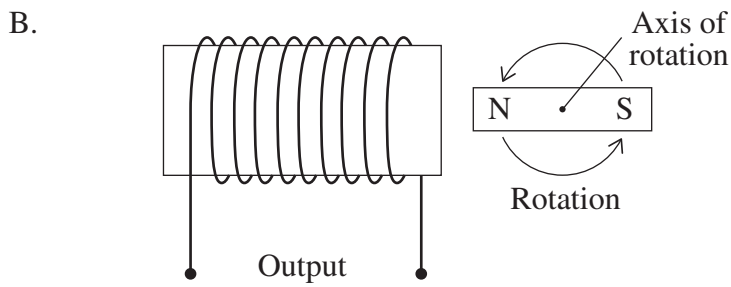
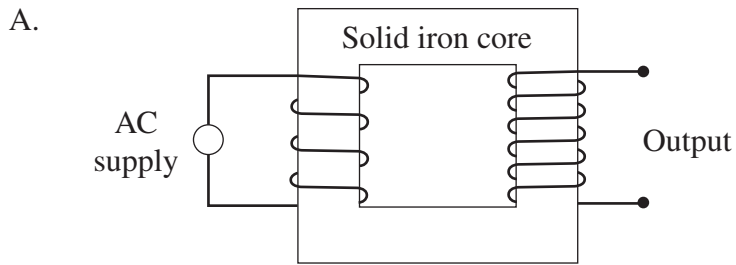

- 8 A uranium isotope, U , undergoes four successive decays to produce Q .

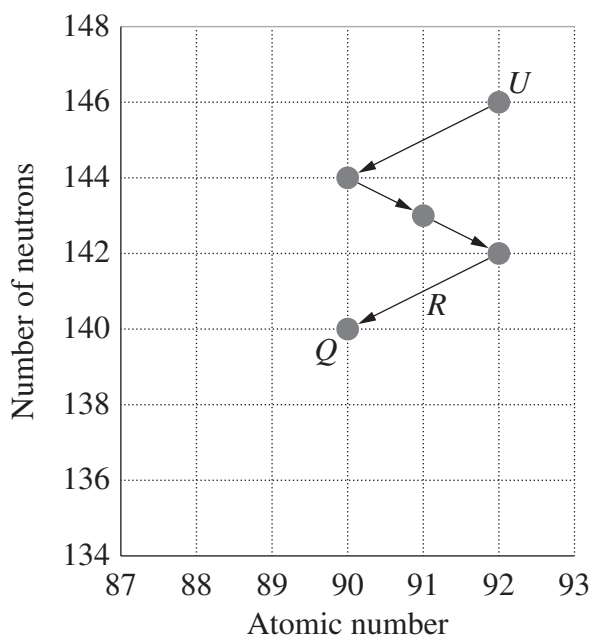

Which row of the table correctly shows the decay process R and product Q ?

	<i>Process R</i>	<i>Product Q</i>
A.	α	Pa-230
B.	β	Pa-234
C.	α	Th-230
D.	β	Th-234

- 9 Bohr improved on Rutherford's model of the atom.

Which observation by Bohr provided evidence supporting the improvement?

- A. Elements produced unique emission spectra consisting of discrete wavelengths.
- B. The collision of an electron and a positron produced two photons that travelled in opposite directions.
- C. A small percentage of alpha particles fired at a gold foil target were deflected by angles of more than 90 degrees.
- D. A beam of electrons reflected from a nickel crystal produced a pattern of intensity at different angles, consistent with their wave properties.

- 10 An electron travelling in a straight line with an initial velocity, u , enters a region between two charged plates in which there is an electric field causing it to travel along the path as shown.

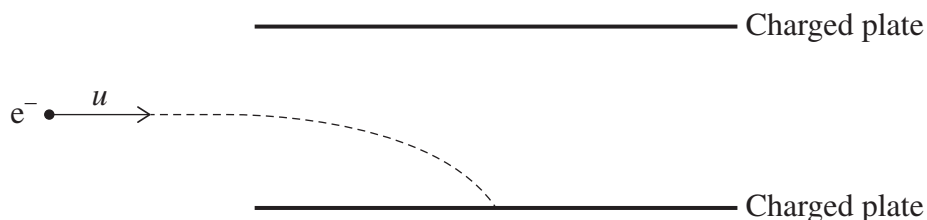

A magnetic field is then applied causing a second electron with the same initial velocity to pass through undeflected.

Which row of the table shows the directions of the electric and magnetic fields when the second electron enters the region between the plates?

	<i>Electric field</i>	<i>Magnetic field</i>
A.	Towards top of page	Into page
B.	Towards top of page	Out of page
C.	Towards bottom of page	Into page
D.	Towards bottom of page	Out of page

- 11 Consider the following nuclear reaction.

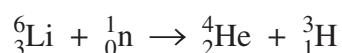

The mass of the reactants is $7.023787704 u$ and the mass of the products is $7.018652532 u$.

What type of reaction is this?

- A. A fusion reaction in which energy is released
- B. A fusion reaction that requires an input of energy
- C. A transmutation reaction in which energy is released
- D. A transmutation reaction that requires an input of energy

12 In which of the following would the satellite have the greatest escape velocity from Earth?

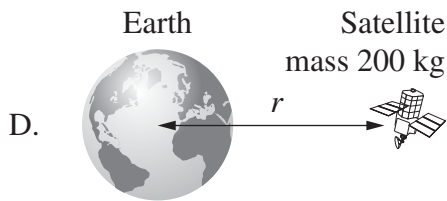
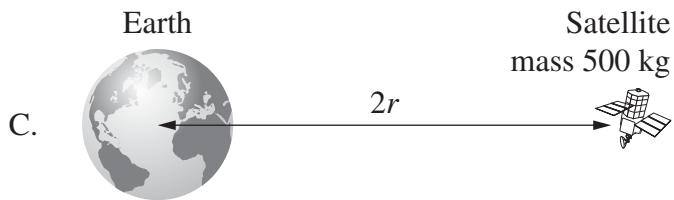
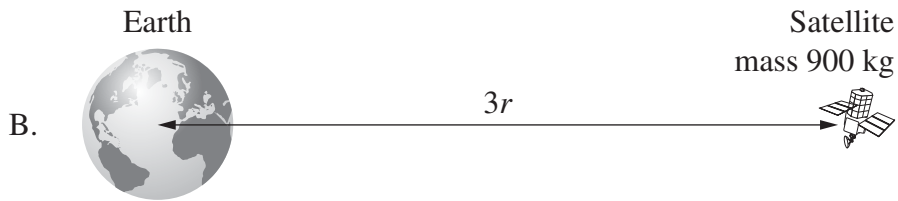
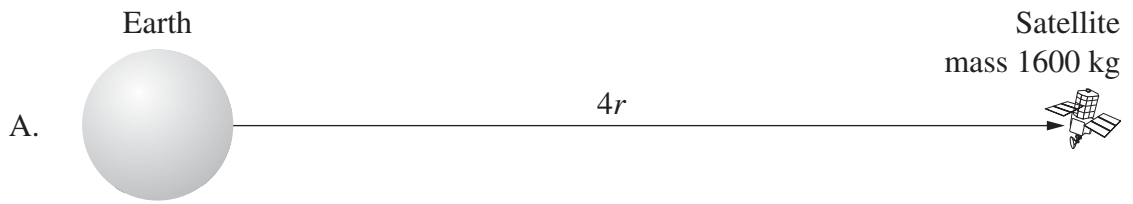

- 13 The graph shows the relationship between the frequency of light used to irradiate two different metals, and the maximum kinetic energy of photoelectrons emitted.

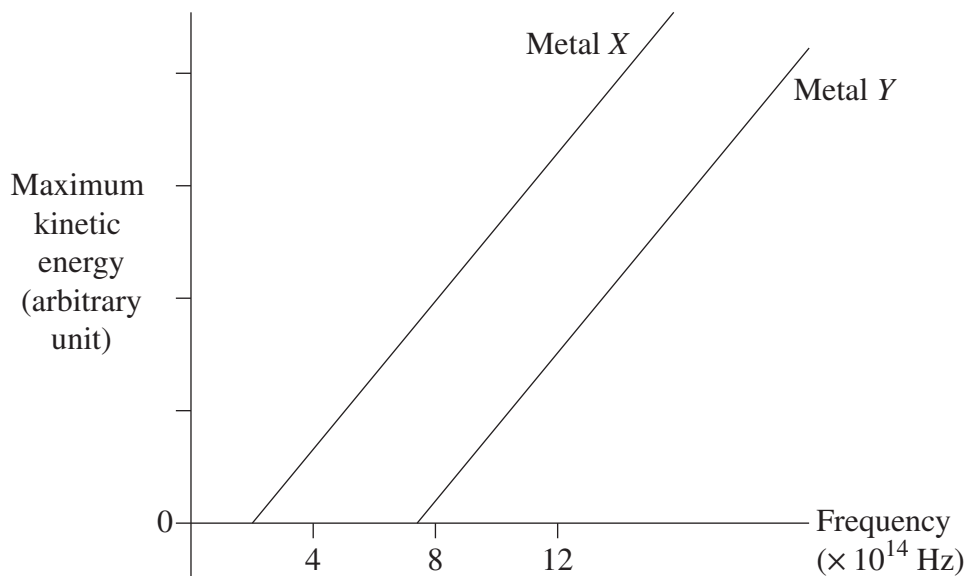

Suppose that light having a frequency of 8×10^{14} Hz is used to irradiate both metals.

Compared to the photoelectrons emitted from metal X, photoelectrons emitted from metal Y will

- A. have a lower maximum velocity.
- B. have a higher maximum velocity.
- C. take a longer time to gain sufficient energy to be ejected.
- D. take a shorter time to gain sufficient energy to be ejected.

- 14 Two parallel wires, X and Y , each carry a current I .

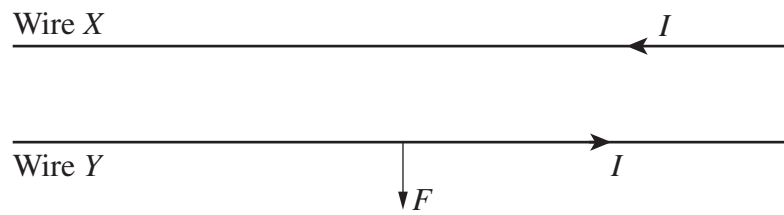

The magnitude and direction of the force on wire Y are represented by the vector F .

The current in wire Y is then doubled and its direction is reversed. The current in wire X remains unchanged.

Which vector arrow represents the force on wire X after the change to the current in wire Y ?

A.



B.



C.



D.



- 15 A rocket returns to Earth for reuse after launching satellites, using its engines to make a controlled landing.

The rocket having a mass of 7800 kg is on approach to the ground, travelling horizontally at 20 m s^{-1} as shown in the diagram, when the engine thrust is changed to 90 000 newtons.

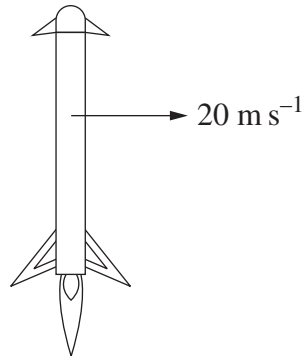

Which diagram shows the trajectory of the rocket following this change of thrust?

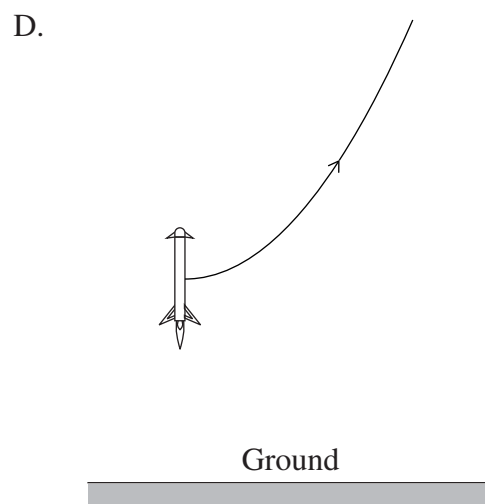
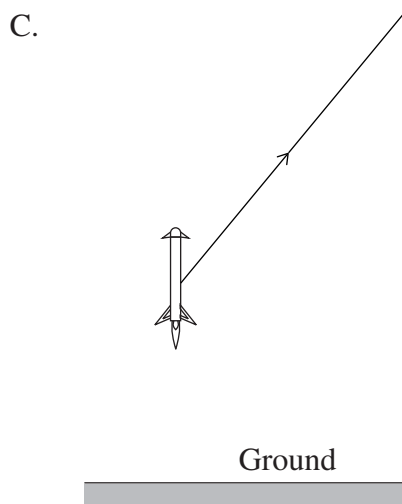
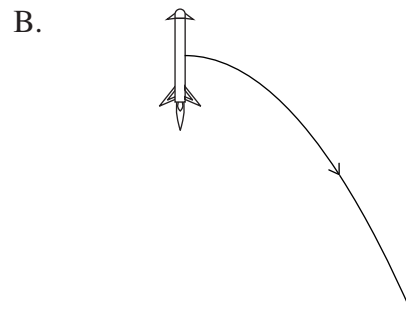
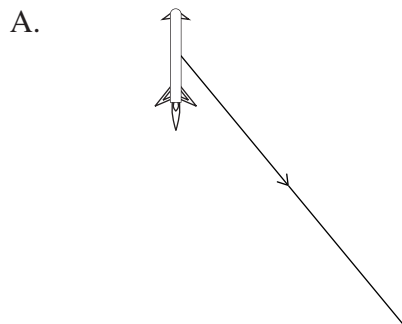

16 A model of the core of a nuclear fission reactor is shown.

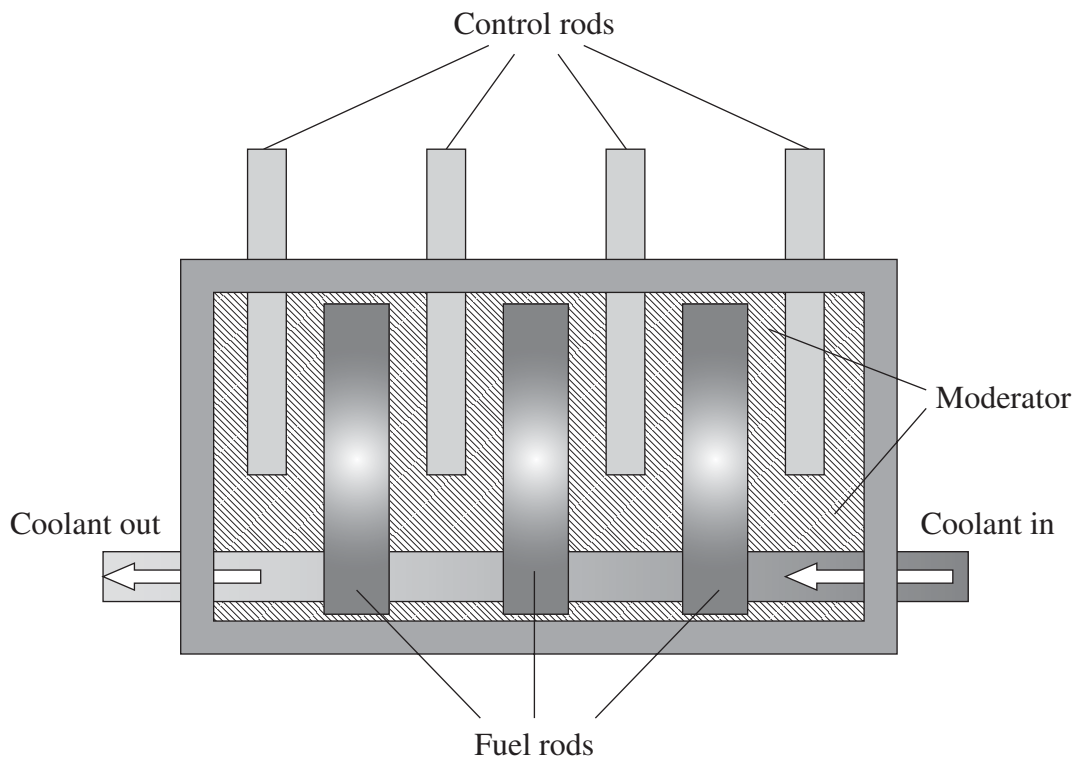

When the reactor is operating normally, the moderator, control rods and coolant work in combination to maintain a controlled nuclear reaction in the fuel rods.

The moderator is a liquid which slows down neutrons to increase the rate of fission. The control rods absorb free neutrons. The coolant reduces the core temperature.

A fault causes some of the moderator to leak out of the core.

Which action would compensate for the effect of the loss of moderator?

- A. Withdraw the control rods from the core.
- B. Lower the control rods further into the core.
- C. Pump the coolant through the core at a faster rate.
- D. Reduce the temperature of the coolant before pumping it into the core.

- 17 In a thought experiment, observer X is on a train travelling at a constant velocity of $0.95c$ relative to the ground. Observer Y is standing on the ground outside the train. As observer X passes observer Y , observer X sends a short light pulse towards the sensor.

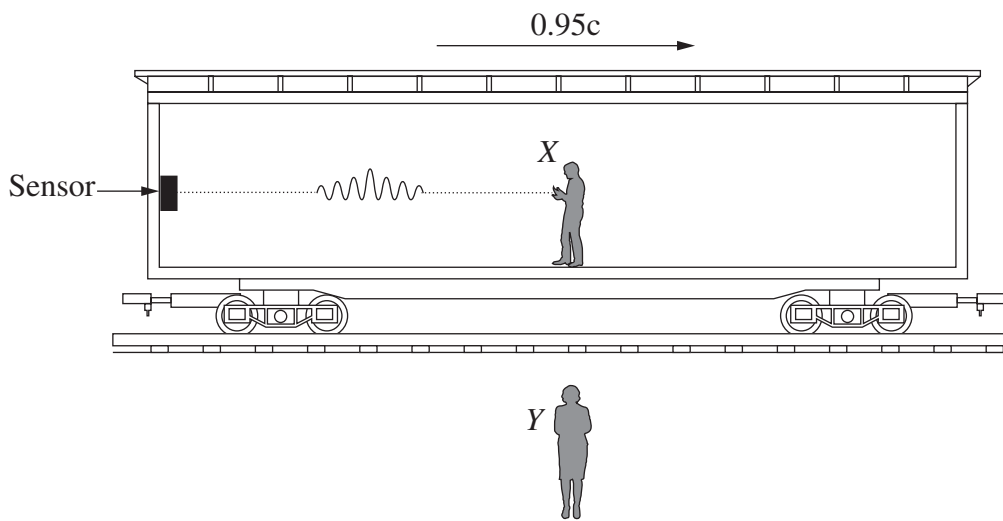

Which statement about the light pulse is correct as observed by X or Y in their respective frames of reference?

- A. Its velocity observed by Y is $0.05c$.
- B. X sees it travel a shorter distance to the sensor than Y .
- C. X sees it take a longer time to reach the sensor than Y .
- D. Both X and Y see it travel the same distance in the same amount of time.

- 18 An observer sees Io complete one orbit of Jupiter as Earth moves from P_1 to P_2 , and records the observed orbital period as t_P . Similarly, the time for one orbit of Io around Jupiter was measured as Earth moved between the pairs of points at Q, R and S , with the corresponding measured periods of Io being t_Q, t_R and t_S .

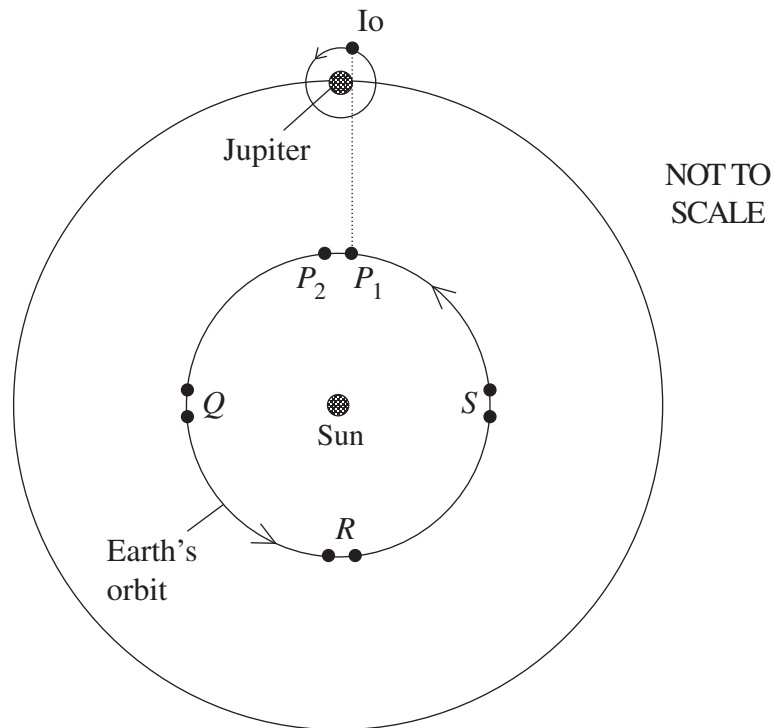

Which measurement of the orbital period would be the longest?

- A. t_P
- B. t_Q
- C. t_R
- D. t_S

- 19 A conductor PQ is in a uniform magnetic field. The conductor rotates around the end P at a constant angular velocity.

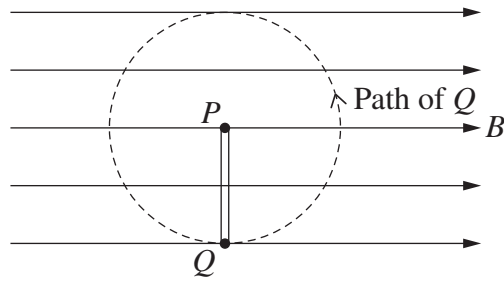

Which graph shows the induced emf between P and Q as the conductor completes one revolution from the position shown?

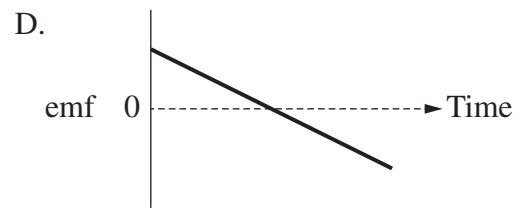
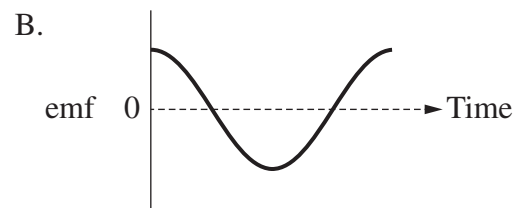
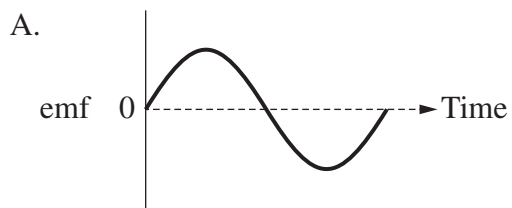

20 The diagram shows a smooth, semi-circular, vertical wall with radius, r .

A ball is launched from the position shown with a velocity u towards north at an angle to the horizontal.

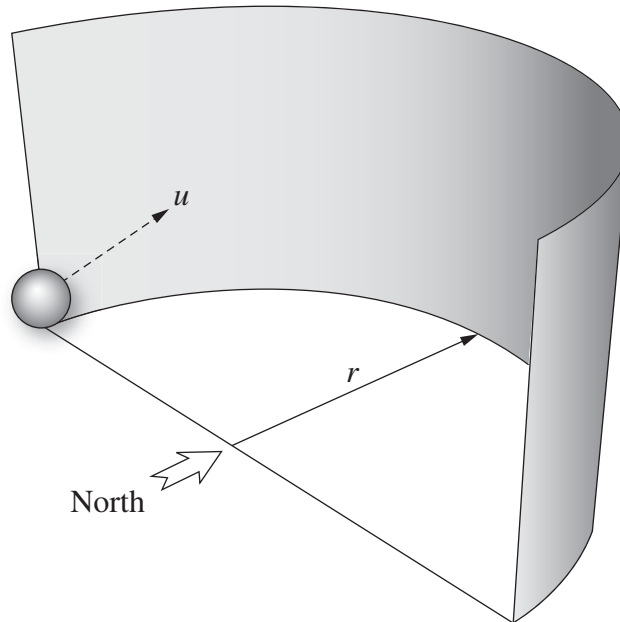

The ball follows a trajectory around the wall before landing on the ground, opposite its starting point. It does not reach the top of the wall.

Assume that there is no friction between the ball and the wall.

Which statement correctly describes the net force acting on the ball during its motion?

- A. The magnitude of the net force remains constant.
- B. The direction of the net force is vertically downwards.
- C. The direction of the net force is perpendicular to the wall.
- D. The magnitude of the net force reaches a minimum when the ball is at its highest point.

--	--	--	--	--

Centre Number

Physics

--	--	--	--	--	--	--	--	--

Student Number

Section II Answer Booklet

80 marks

Attempt Questions 21–34

Allow about 2 hours and 25 minutes for this section

Instructions

- Write your Centre Number and Student Number at the top of this page.
- Answer the questions in the spaces provided. These spaces provide guidance for the expected length of response.
- Show all relevant working in questions involving calculations.
- Extra writing space is provided at the back of this booklet. If you use this space, clearly indicate which question you are answering.

Please turn over

Question 21 (5 marks)

- (a) Calculate the wavelength of light emitted by an electron moving from energy level 3 to 2 in a Bohr model hydrogen atom. 2

.....

.....

.....

.....

.....

.....

.....

- (b) Describe the behaviour of electrons in the Bohr model of the atom with reference to the law of conservation of energy. 3

.....

.....

.....

.....

.....

.....

.....

Do NOT write in this area.

Question 22 (5 marks)

A capsule travelling at $12\,900\text{ m s}^{-1}$ enters Earth's atmosphere, causing it to rapidly slow down to 400 m s^{-1} .

- (a) During this re-entry, the capsule reaches a temperature of 3200 K . **2**

What is the peak wavelength of the light emitted by the capsule?

.....
.....
.....
.....

- (b) Outline TWO limitations of applying special relativity to the analysis of the motion of the capsule. **3**

.....
.....
.....
.....
.....
.....

Question 23 (3 marks)

The graph shows data for a motor connected to a 240 V power supply.

3

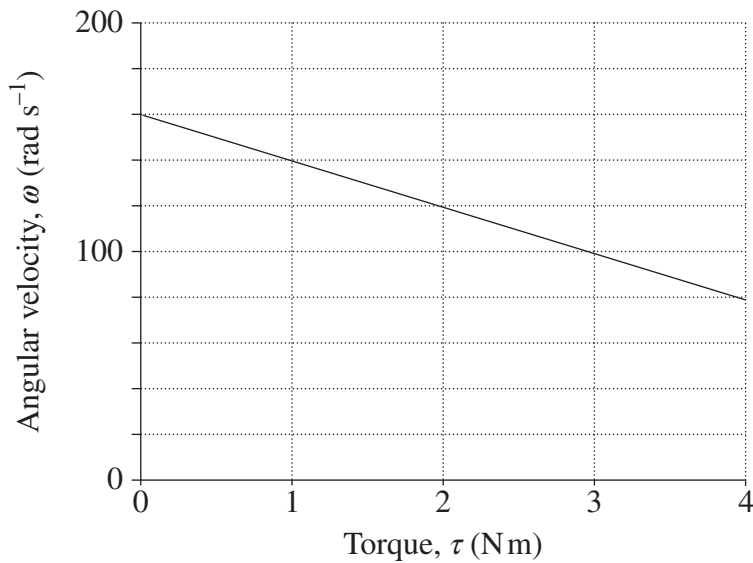

The equation for the torque, τ , produced by the motor is $\tau = \frac{VI\eta}{\omega}$

- where τ = torque (Nm)
- V = voltage (V)
- I = current (A)
- η = efficiency = 0.3
- ω = angular velocity (rad s⁻¹)

A circuit breaker cuts the current to the motor if the current exceeds 5 A.

Determine what will happen when the motor produces a torque of 2.95 Nm. Show relevant calculations.

.....

.....

.....

.....

.....

.....

.....

Do NOT write in this area.

Question 24 (4 marks)

The graph shows the vertical displacement of a projectile throughout its trajectory. The range of the projectile is 130 m.

4

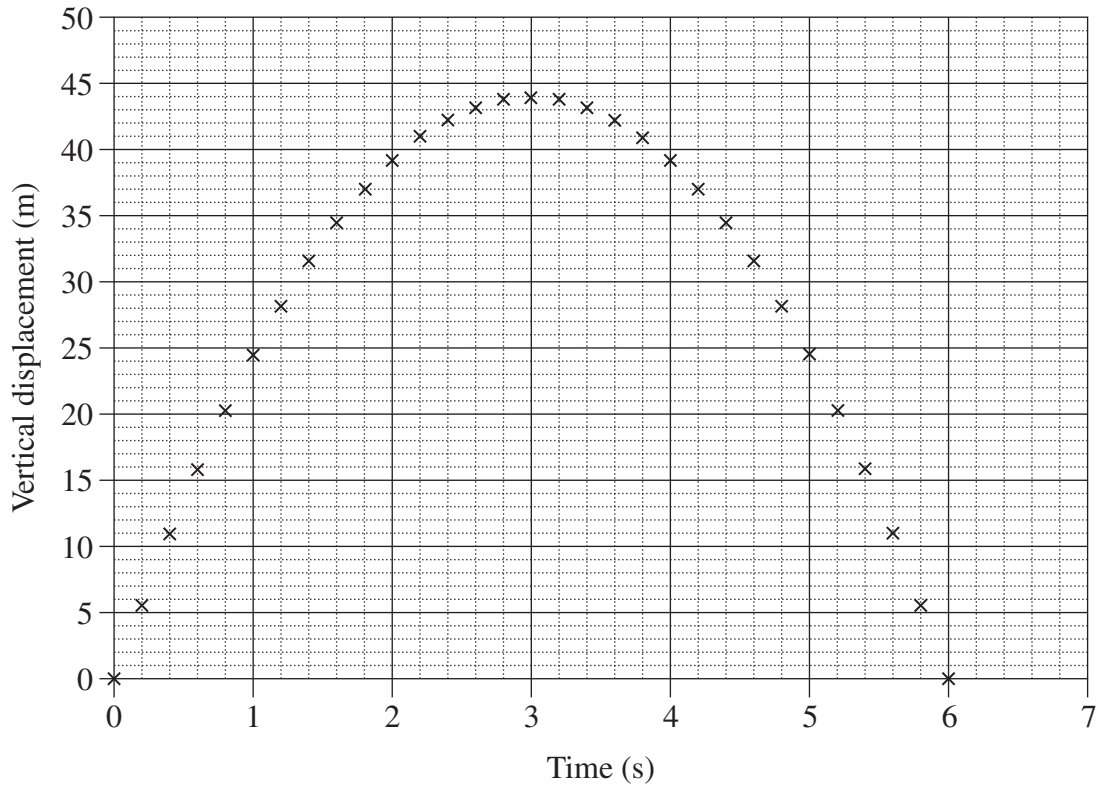

Calculate the initial velocity of the projectile.

.....

.....

.....

.....

.....

.....

.....

.....

.....

.....

.....

.....

.....

.....

.....

.....

.....

.....

.....

.....

.....

.....

Do NOT write in this area.

Question 25 (4 marks)

Describe the hydrogen atom in terms of the Standard Model of matter.

4

.....

.....

.....

.....

.....

.....

.....

.....

.....

.....

.....

.....

.....

.....

.....

Do NOT write in this area.

Do NOT write in this area.

Question 26 (8 marks)

- (a) Describe the difference between the spectra of the light produced by a gas discharge tube and by an incandescent lamp. 2

.....

.....

.....

.....

- (b) The graph shows the curves predicted by two different models, X and Y, for the electromagnetic radiation emitted by an object at a temperature of 5000 K. 2

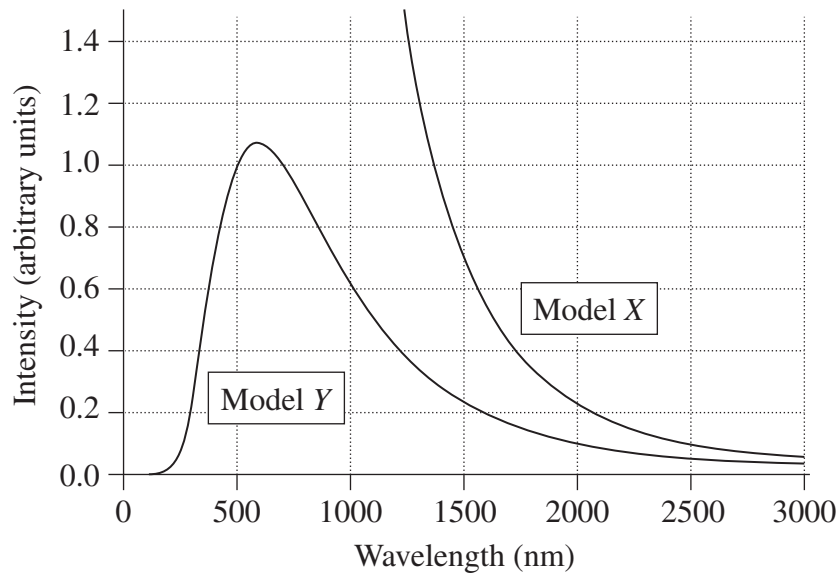

Identify an assumption of EACH model which determines the shape of its curve.

.....

.....

.....

.....

Question 26 continues on page 24

Question 26 (continued)

- (c) The diagram shows the radiation curve for a black body radiator at a temperature of 5000 K.

4

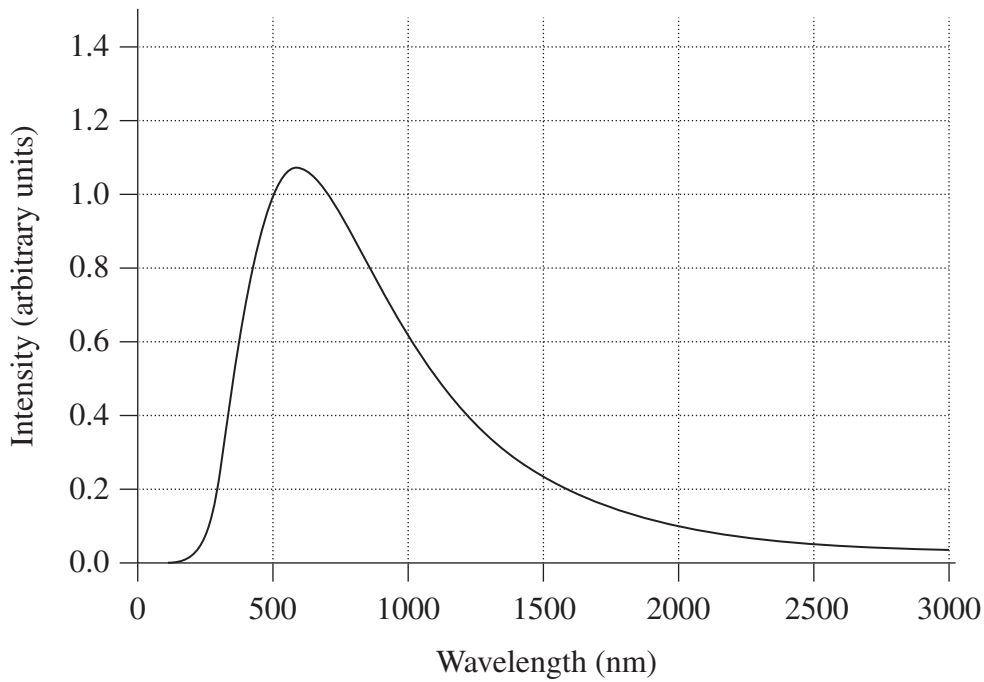

On the same diagram, sketch a curve for a black body radiator at a temperature of 4000 K and explain the differences between the curves.

.....

.....

.....

.....

.....

.....

.....

.....

.....

.....

.....

End of Question 26

Question 27 (4 marks)

The following apparatus is used to investigate light interference using a double slit.

4

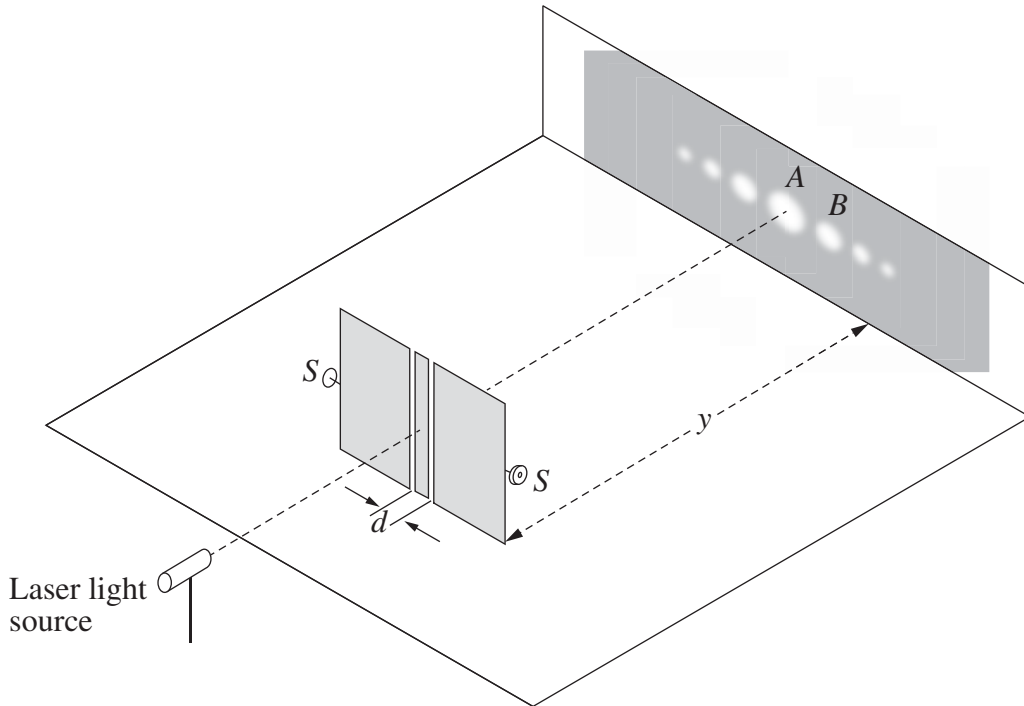

The distance, y , from the slits to the screen can be varied. The adjustment screws (S) vary the distance, d , between the slits. The wavelength of the laser light can be varied across the visible spectrum. The diffraction pattern shown is for a specific wavelength of light.

Explain TWO methods of keeping the distance between the maxima at A and B constant when the wavelength of the laser light is reduced.

.....

.....

.....

.....

.....

.....

.....

.....

.....

.....

.....

.....

.....

.....

.....

.....

.....

.....

.....

.....

.....

Do NOT write in this area.

Question 28 (7 marks)

A metal rod sits on a pair of parallel metal rails, 20 cm apart, that are connected by a copper wire. The rails are at 30° to the horizontal.

The apparatus is in a uniform magnetic field of 1 T which is upward, perpendicular to the table.

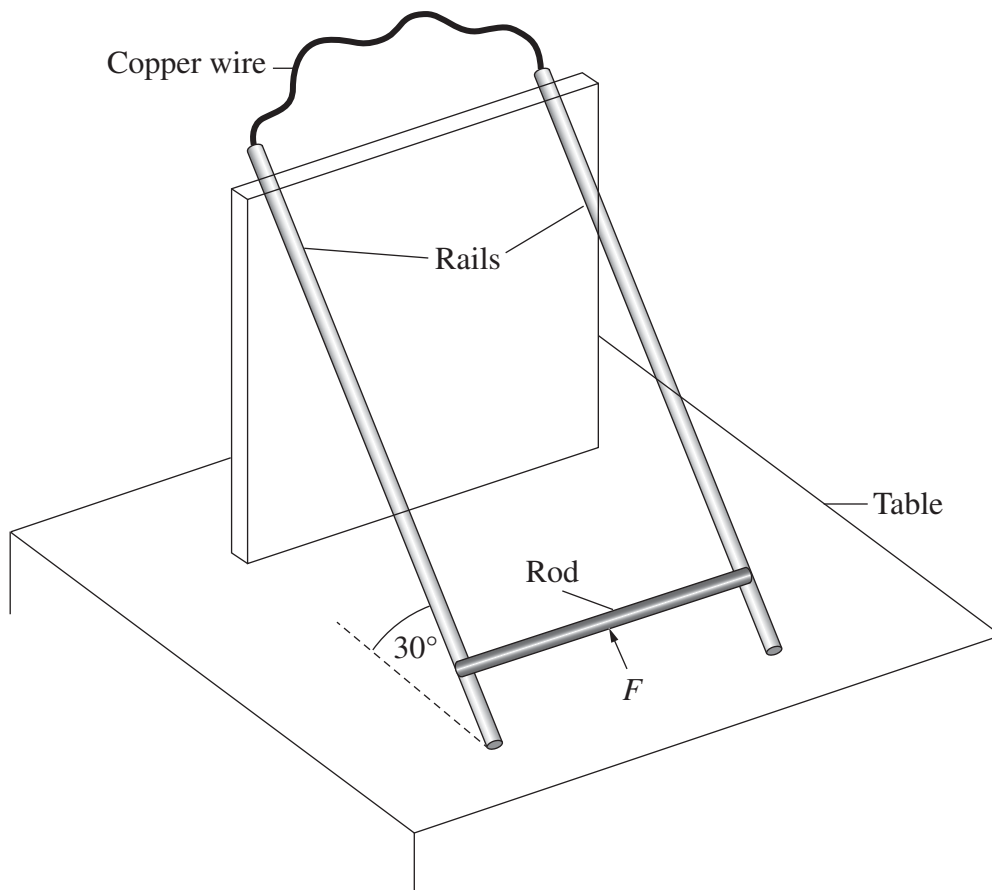

A force, F , is applied parallel to the rails to move the rod at a constant speed along the rails. The rod is moved a distance of 30 cm in 2.5 s.

- (a) Show that the change in magnetic flux through the circuit while the rod is moving is approximately 5.2×10^{-2} Wb. 2

.....

.....

.....

.....

Question 28 continues on page 27

Do NOT write in this area.

Question 28 (continued)

- (b) Calculate the emf induced between the ends of the rod while it is moving, and state the direction of flow of the current in the circuit. 2

.....
.....
.....
.....

- (c) The experiment is repeated without the magnetic field. 3

Explain why the force required to move the rod is different without the magnetic field.

.....
.....
.....
.....
.....
.....

End of Question 28

Question 29 (5 marks)

In an experiment, alpha particles were fired into a thin sheet of beryllium. Unknown radiation was detected.

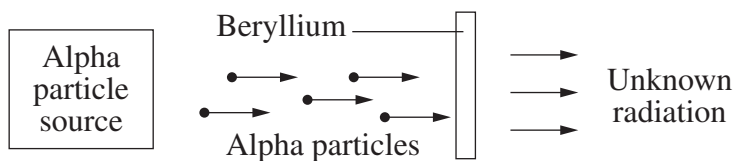

Further experiments were conducted in which it was observed that the unknown radiation:

- was not deflected by an electric field
- caused protons to be ejected from a block of paraffin
- could not produce the photoelectric effect.

Scientists debated the nature of this unknown radiation, hypothesising that it was gamma radiation.

(a) Explain why the hypothesis was proposed and then rejected, with reference to the observations. 3

.....

.....

.....

.....

.....

.....

.....

.....

.....

.....

.....

.....

.....

.....

(b) How did these experiments change the model of the atom? 2

.....

.....

.....

.....

Do NOT write in this area.

Question 30 (7 marks)

- (a) Explain, using an example, how a particle accelerator has provided evidence for the Standard Model of matter. **3**

.....

.....

.....

.....

.....

.....

.....

- (b) (i) Calculate the wavelength of a proton travelling at $0.1c$. **2**

.....

.....

.....

.....

.....

- (ii) Explain the relativistic effect on the wavelength of a proton travelling at $0.95c$. **2**

.....

.....

.....

.....

.....

Question 31 (6 marks)

- (a) The orbit of a comet is shown.

3

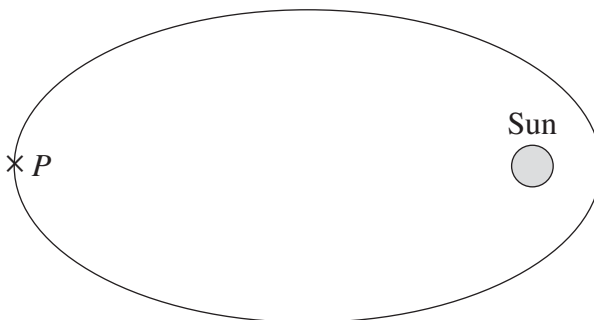

Account for the changes in velocity of the comet as it completes one orbit from position P .

.....
.....
.....
.....
.....
.....
.....

- (b) Two stars, A and B , of equal mass m , separated by a distance x , interact gravitationally such that the speed of A is constant.

3

Derive an expression for the speed of B .

.....
.....
.....
.....
.....
.....
.....

Do NOT write in this area.

Question 32 (7 marks)

A rope connects a mass on a horizontal surface to a pulley attached to an electric motor as shown.

7

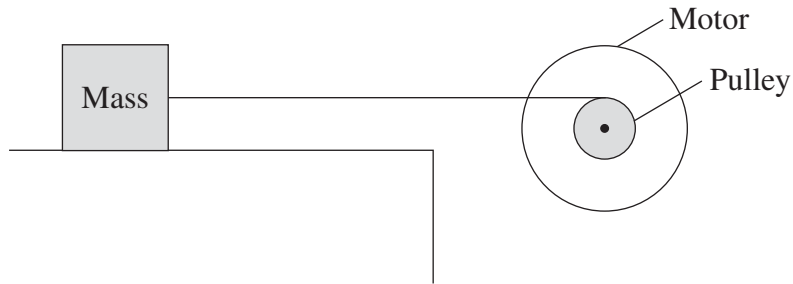

Explain the factors that limit the speed at which the mass can be pulled along the horizontal surface. Use mathematical models to support your answer.

.....

.....

.....

.....

.....

.....

.....

.....

.....

.....

.....

.....

.....

.....

.....

.....

.....

.....

.....

.....

.....

.....

.....

.....

.....

Do NOT write in this area.

Question 33 (9 marks)

A strong magnet of mass 0.04 kg falls 0.78 m under the action of gravity from position *X* above a hollow copper cylinder. It then travels a distance of 0.20 m through the cylinder from *Y* to *Z* before falling freely again.

9

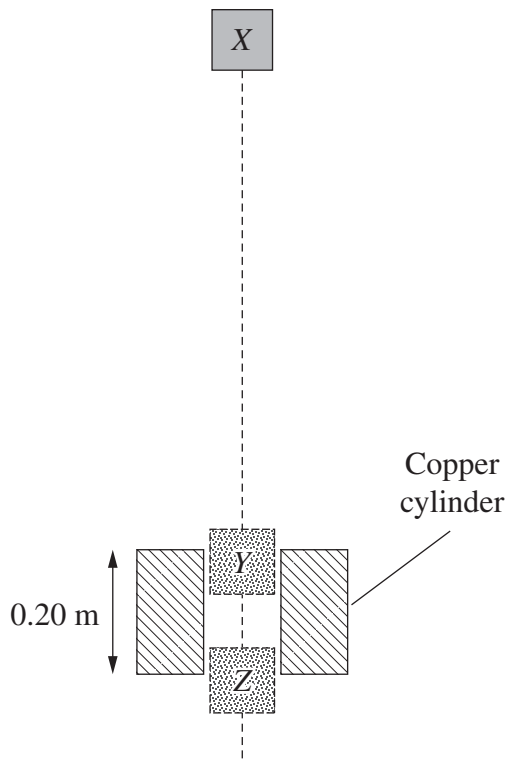

The magnet takes 0.5 seconds to pass through the cylinder. The displacement–time graph of the magnet is shown.

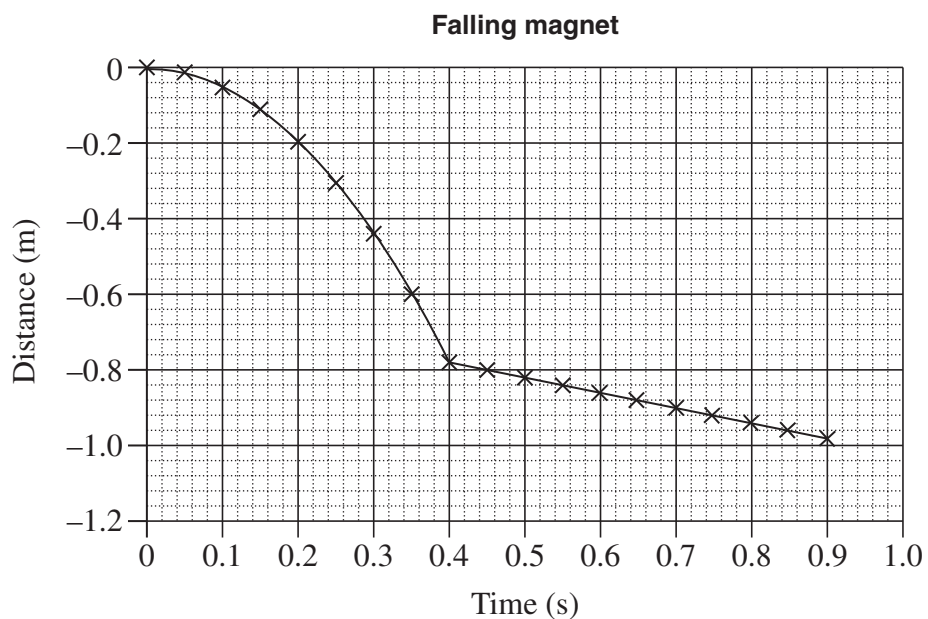

Question 33 continues on page 33

Question 33 (continued)

Analyse the motion of the magnet by applying the law of conservation of energy.

Your analysis should refer to gravity and the copper cylinder, and include both qualitative and quantitative information.

.....

.....

.....

.....

.....

.....

.....

.....

.....

.....

.....

.....

.....

.....

.....

.....

.....

.....

.....

.....

.....

.....

.....

.....

Do NOT write in this area.

End of Question 33

Question 34 (6 marks)

A charged particle, q_1 , is fired midway between oppositely charged plates X and Y , as shown in Figure 1. The voltage between the plates is V volts.

The particle strikes plate Y at point P , a horizontal distance s from the edge of the plate. Ignore the effect of gravity.

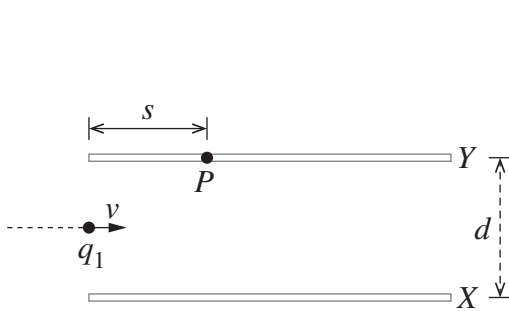

Figure 1

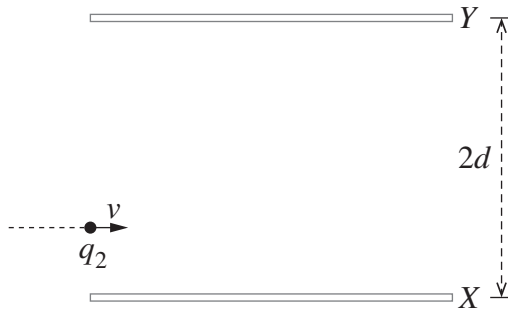

Figure 2

Plate Y is then moved to the position shown in Figure 2, with the voltage between the plates remaining the same.

An identical particle, q_2 , is fired into the electric field at the same velocity, entering the field at the same distance from plate X as q_1 .

- (a) Compare the work done on q_1 and q_2 .

3

.....

.....

.....

.....

.....

.....

.....

.....

.....

.....

Question 34 continues on page 35

Question 34 (continued)

- (b) Compare the horizontal distances travelled by q_1 and q_2 in the electric field. 3

.....

.....

.....

.....

.....

.....

.....

.....

.....

.....

.....

.....

.....

.....

.....

End of paper

Do NOT write in this area.

Section II extra writing space

If you use this space, clearly indicate which question you are answering.

Do NOT write in this area.

Physics

DATA SHEET

Charge on electron, q_e	$-1.602 \times 10^{-19} \text{ C}$
Mass of electron, m_e	$9.109 \times 10^{-31} \text{ kg}$
Mass of neutron, m_n	$1.675 \times 10^{-27} \text{ kg}$
Mass of proton, m_p	$1.673 \times 10^{-27} \text{ kg}$
Speed of sound in air	340 m s^{-1}
Earth's gravitational acceleration, g	9.8 m s^{-2}
Speed of light, c	$3.00 \times 10^8 \text{ m s}^{-1}$
Electric permittivity constant, ϵ_0	$8.854 \times 10^{-12} \text{ A}^2 \text{ s}^4 \text{ kg}^{-1} \text{ m}^{-3}$
Magnetic permeability constant, μ_0	$4\pi \times 10^{-7} \text{ N A}^{-2}$
Universal gravitational constant, G	$6.67 \times 10^{-11} \text{ N m}^2 \text{ kg}^{-2}$
Mass of Earth, M_E	$6.0 \times 10^{24} \text{ kg}$
Radius of Earth, r_E	$6.371 \times 10^6 \text{ m}$
Planck constant, h	$6.626 \times 10^{-34} \text{ J s}$
Rydberg constant, R (hydrogen)	$1.097 \times 10^7 \text{ m}^{-1}$
Atomic mass unit, u	$1.661 \times 10^{-27} \text{ kg}$ $931.5 \text{ MeV}/c^2$
1 eV	$1.602 \times 10^{-19} \text{ J}$
Density of water, ρ	$1.00 \times 10^3 \text{ kg m}^{-3}$
Specific heat capacity of water	$4.18 \times 10^3 \text{ J kg}^{-1} \text{ K}^{-1}$
Wien's displacement constant, b	$2.898 \times 10^{-3} \text{ m K}$

FORMULAE SHEET

Motion, forces and gravity

$$s = ut + \frac{1}{2}at^2$$

$$v^2 = u^2 + 2as$$

$$\Delta U = mg\Delta h$$

$$P = \frac{\Delta E}{\Delta t}$$

$$\sum \frac{1}{2}mv_{\text{before}}^2 = \sum \frac{1}{2}mv_{\text{after}}^2$$

$$\Delta \vec{p} = \vec{F}_{\text{net}} \Delta t$$

$$\omega = \frac{\Delta \theta}{t}$$

$$\tau = r_{\perp} F = rF \sin \theta$$

$$v = \frac{2\pi r}{T}$$

$$U = -\frac{GMm}{r}$$

$$v = u + at$$

$$\vec{F}_{\text{net}} = m\vec{a}$$

$$W = F_{\parallel} s = Fs \cos \theta$$

$$K = \frac{1}{2}mv^2$$

$$P = F_{\parallel} v = Fv \cos \theta$$

$$\sum m\vec{v}_{\text{before}} = \sum m\vec{v}_{\text{after}}$$

$$a_c = \frac{v^2}{r}$$

$$F_c = \frac{mv^2}{r}$$

$$F = \frac{GMm}{r^2}$$

$$\frac{r^3}{T^2} = \frac{GM}{4\pi^2}$$

Waves and thermodynamics

$$v = f\lambda$$

$$f = \frac{1}{T}$$

$$d \sin \theta = m\lambda$$

$$n_x = \frac{c}{v_x}$$

$$I = I_{\text{max}} \cos^2 \theta$$

$$Q = mc\Delta T$$

$$f_{\text{beat}} = |f_2 - f_1|$$

$$f' = f \frac{(v_{\text{wave}} + v_{\text{observer}})}{(v_{\text{wave}} - v_{\text{source}})}$$

$$n_1 \sin \theta_1 = n_2 \sin \theta_2$$

$$\sin \theta_c = \frac{n_2}{n_1}$$

$$I_1 r_1^2 = I_2 r_2^2$$

$$\frac{Q}{t} = \frac{kA\Delta T}{d}$$

FORMULAE SHEET (continued)

Electricity and magnetism

$$E = \frac{V}{d}$$

$$V = \frac{\Delta U}{q}$$

$$W = qV$$

$$W = qEd$$

$$B = \frac{\mu_0 I}{2\pi r}$$

$$B = \frac{\mu_0 NI}{L}$$

$$\Phi = B_{\parallel} A = BA \cos\theta$$

$$\mathcal{E} = -N \frac{\Delta\Phi}{\Delta t}$$

$$\frac{V_p}{V_s} = \frac{N_p}{N_s}$$

$$\vec{F} = q\vec{E}$$

$$F = \frac{1}{4\pi\epsilon_0} \frac{q_1 q_2}{r^2}$$

$$I = \frac{q}{t}$$

$$V = IR$$

$$P = VI$$

$$F = qv_{\perp} B = qvB \sin\theta$$

$$F = I l_{\perp} B = I l B \sin\theta$$

$$\frac{F}{l} = \frac{\mu_0}{2\pi} \frac{I_1 I_2}{r}$$

$$\tau = n I A_{\perp} B = n I A B \sin\theta$$

$$V_p I_p = V_s I_s$$

Quantum, special relativity and nuclear

$$\lambda = \frac{h}{mv}$$

$$K_{\max} = hf - \phi$$

$$\lambda_{\max} = \frac{b}{T}$$

$$E = mc^2$$

$$E = hf$$

$$\frac{1}{\lambda} = R \left(\frac{1}{n_f^2} - \frac{1}{n_i^2} \right)$$

$$t = \frac{t_0}{\sqrt{\left(1 - \frac{v^2}{c^2}\right)}}$$

$$l = l_0 \sqrt{\left(1 - \frac{v^2}{c^2}\right)}$$

$$p_v = \frac{m_0 v}{\sqrt{\left(1 - \frac{v^2}{c^2}\right)}}$$

$$N_t = N_0 e^{-\lambda t}$$

$$\lambda = \frac{\ln 2}{t_{\frac{1}{2}}}$$

PERIODIC TABLE OF THE ELEMENTS

1 H 1.008 Hydrogen	KEY Atomic Number: 79 Symbol: Au Standard Atomic Weight: 197.0 Name: Gold																2 He 4.003 Helium
3 Li 6.941 Lithium	4 Be 9.012 Beryllium											5 B 10.81 Boron	6 C 12.01 Carbon	7 N 14.01 Nitrogen	8 O 16.00 Oxygen	9 F 19.00 Fluorine	10 Ne 20.18 Neon
11 Na 22.99 Sodium	12 Mg 24.31 Magnesium											13 Al 26.98 Aluminium	14 Si 28.09 Silicon	15 P 30.97 Phosphorus	16 S 32.07 Sulfur	17 Cl 35.45 Chlorine	18 Ar 39.95 Argon
19 K 39.10 Potassium	20 Ca 40.08 Calcium	21 Sc 44.96 Scandium	22 Ti 47.87 Titanium	23 V 50.94 Vanadium	24 Cr 52.00 Chromium	25 Mn 54.94 Manganese	26 Fe 55.85 Iron	27 Co 58.93 Cobalt	28 Ni 58.69 Nickel	29 Cu 63.55 Copper	30 Zn 65.38 Zinc	31 Ga 69.72 Gallium	32 Ge 72.64 Germanium	33 As 74.92 Arsenic	34 Se 78.96 Selenium	35 Br 79.90 Bromine	36 Kr 83.80 Krypton
37 Rb 85.47 Rubidium	38 Sr 87.61 Strontium	39 Y 88.91 Yttrium	40 Zr 91.22 Zirconium	41 Nb 92.91 Niobium	42 Mo 95.96 Molybdenum	43 Tc 95.96 Technetium	44 Ru 101.1 Ruthenium	45 Rh 102.9 Rhodium	46 Pd 106.4 Palladium	47 Ag 107.9 Silver	48 Cd 112.4 Cadmium	49 In 114.8 Indium	50 Sn 118.7 Tin	51 Sb 121.8 Antimony	52 Te 127.6 Tellurium	53 I 126.9 Iodine	54 Xe 131.3 Xenon
55 Cs 132.9 Caesium	56 Ba 137.3 Barium	57–71 Lanthanoids	72 Hf 178.5 Hafnium	73 Ta 180.9 Tantalum	74 W 183.9 Tungsten	75 Re 186.2 Rhenium	76 Os 190.2 Osmium	77 Ir 192.2 Iridium	78 Pt 195.1 Platinum	79 Au 197.0 Gold	80 Hg 200.6 Mercury	81 Tl 204.4 Thallium	82 Pb 207.2 Lead	83 Bi 209.0 Bismuth	84 Po 209.0 Polonium	85 At 209.0 Astatine	86 Rn 209.0 Radon
87 Fr 223.0 Francium	88 Ra 226.0 Radium	89–103 Actinoids	104 Rf 261.0 Rutherfordium	105 Db 262.0 Dubnium	106 Sg 263.0 Seaborgium	107 Bh 264.0 Bohrium	108 Hs 265.0 Hassium	109 Mt 266.0 Meitnerium	110 Ds 267.0 Darmstadtium	111 Rg 268.0 Roentgenium	112 Cn 269.0 Copernicium	113 Nh 270.0 Nihonium	114 Fl 271.0 Flerovium	115 Mc 272.0 Moscovium	116 Lv 273.0 Livermorium	117 Ts 274.0 Tennessine	118 Og 275.0 Oganesson

Lanthanoids

57 La 138.9 Lanthanum	58 Ce 140.1 Cerium	59 Pr 140.9 Praseodymium	60 Nd 144.2 Neodymium	61 Pm 144.9 Promethium	62 Sm 150.4 Samarium	63 Eu 152.0 Europium	64 Gd 157.3 Gadolinium	65 Tb 158.9 Terbium	66 Dy 162.5 Dysprosium	67 Ho 164.9 Holmium	68 Er 167.3 Erbium	69 Tm 168.9 Thulium	70 Yb 173.1 Ytterbium	71 Lu 175.0 Lutetium
--------------------------------	-----------------------------	-----------------------------------	--------------------------------	---------------------------------	-------------------------------	-------------------------------	---------------------------------	------------------------------	---------------------------------	------------------------------	-----------------------------	------------------------------	--------------------------------	-------------------------------

Actinoids

89 Ac 227.0 Actinium	90 Th 232.0 Thorium	91 Pa 231.0 Protactinium	92 U 238.0 Uranium	93 Np 237.0 Neptunium	94 Pu 244.0 Plutonium	95 Am 243.0 Americium	96 Cm 247.0 Curium	97 Bk 247.0 Berkelium	98 Cf 251.0 Californium	99 Es 252.0 Einsteinium	100 Fm 257.0 Fermium	101 Md 258.0 Mendelevium	102 No 259.0 Nobelium	103 Lr 260.0 Lawrencium
-------------------------------	------------------------------	-----------------------------------	-----------------------------	--------------------------------	--------------------------------	--------------------------------	-----------------------------	--------------------------------	----------------------------------	----------------------------------	-------------------------------	-----------------------------------	--------------------------------	----------------------------------

Standard atomic weights are abridged to four significant figures.

Elements with no reported values in the table have no stable nuclides.

Information on elements with atomic numbers 113 and above is sourced from the International Union of Pure and Applied Chemistry Periodic Table of the Elements (November 2016 version).

The International Union of Pure and Applied Chemistry Periodic Table of the Elements (February 2010 version) is the principal source of all other data. Some data may have been modified.